



C.L. Smith

a Novvia Group Company



CONTENTS

1

WE ARE CL SMITH

Learn about our heritage, vision, and values that make us an industry leader in packaging.

2

FAMILY OF SOLUTIONS

Our multifaceted family of solutions includes manufacturing, hazardous material certification, design services, and multi-channel distribution.

3

NOVVIA GROUP

The new way of packaging.

4

WRAP UP | Q&A

How can we work together to better serve customers?



1

WE ARE CL SMITH

We'll be fast, even when it's not the industry standard. Flexible, even when others won't give you options. And devoted to your business, because you deserve nothing less.

We are CL Smith; Real People, Real Passion, Real Performance.



OUR VALUES

Delivering value as your partner in packaging solutions.

Authentic

Passionate

Dedicated

Trust

Collaborative

Best in Class

Sense of
Urgency

Focused on
Adding Value

Service to
Others



STRATEGIC COMPETITIVE ADVANTAGES

The building blocks of tomorrow and beyond at CL Smith.



PROUDLY ALL IN FOR YOU

- Unparalleled Care for Customers
- Service is our Passion
- Uniquely Dedicated Employees
- Invest in our Customer's Growth
- Rapid Responsiveness & Decision Making

THE COMPLETE PACKAGE

- Custom Manufacturer
- Full line of stock products
- Flexible and reliable deliver options
- Supply Chain Management
- Exceptional value

HAZARDOUS & PERFORMANCE PACKAGING

- Technical Expertise
- Regulatory knowledge and trusted advice
- Creative Design
- UN Self-certifier and Manufacturer
- Compliance System and Process
- Stock and Custom Options



OUR HISTORY

Delivering value as your partner in packaging solutions.

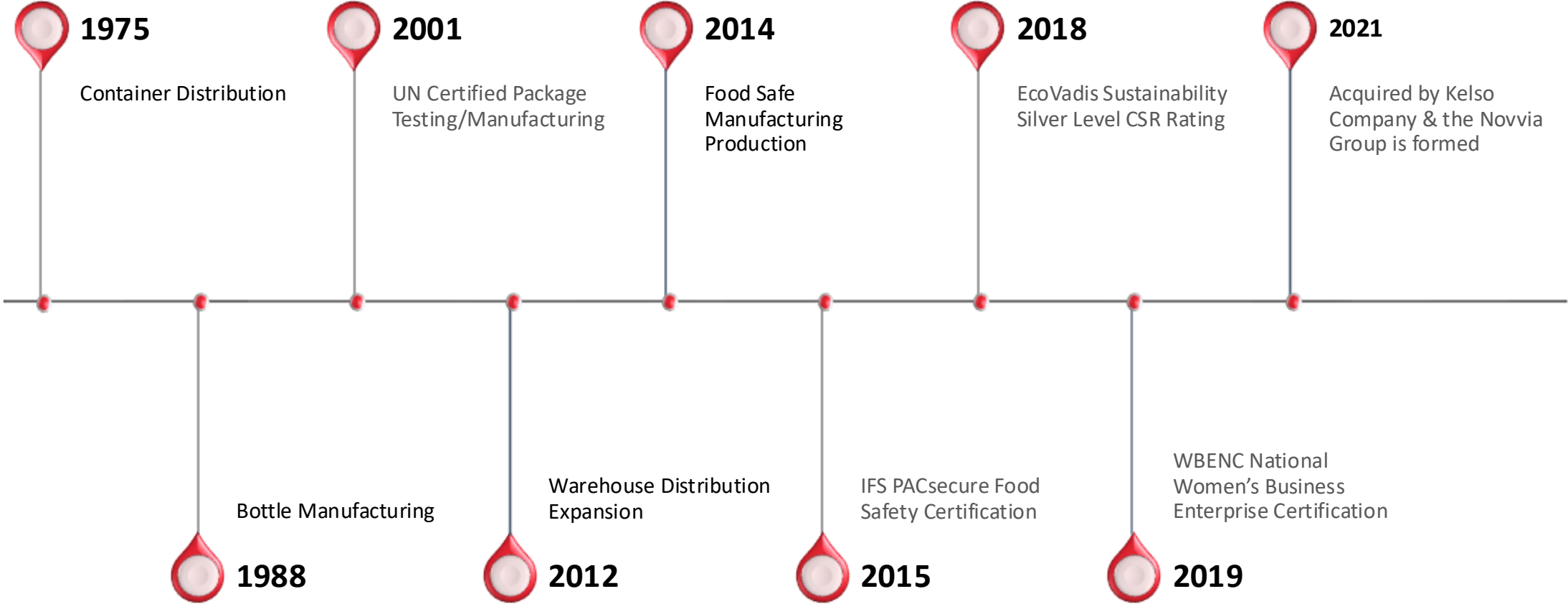



2

FAMILY OF SOLUTIONS

Our multifaceted family of solutions includes manufacturing, hazardous material certification, design services, and multi-channel distribution.



MANUFACTURER

CL Smith Family of Solutions | Making Your Life Easier



MANUFACTURER



UN CERTIFIER



DESIGNER



DISTRIBUTOR



HDPE BOTTLE MANUFACTURING

Delivering value as your partner in packaging solutions.



MANUFACTURING & FINISHED GOODS STORAGE

- 19 Production Lines
- Extrusion Blow Molding/Shuttle
- Multiple Sizes 0.5oz – 10L
- Flexible Quantities & Lead Times
- Automated palletizer for more efficient and cost-effective production

FLEXIBILITY

- Flexible Quantities & Lead Times
- Assorted Packaging Options
- Bulk, Trays, Bins, Re-Shipers
- Custom, Stock, & UN Performance Rated Containers
- Multiple Colors & View Stripe Capabilities
- In-Line Sleeving Decoration
- GFSI IFS PACsecure Food Safety Certification

PRODUCTION

- Operation 24 hours/7 days week
- Diverse Production Team
 - Management
 - Operations
 - Quality Control
 - Shipping/Receiving

QUALITY CONTROL

- Infinity QS – SPC (Statistical Process Control) Technology
- Visual System Inspection, Leak Detection, Visual, Dimensional, Functional, & Destructive Testing





MANUFACTURING ADVANTAGES

Delivering value at every step.

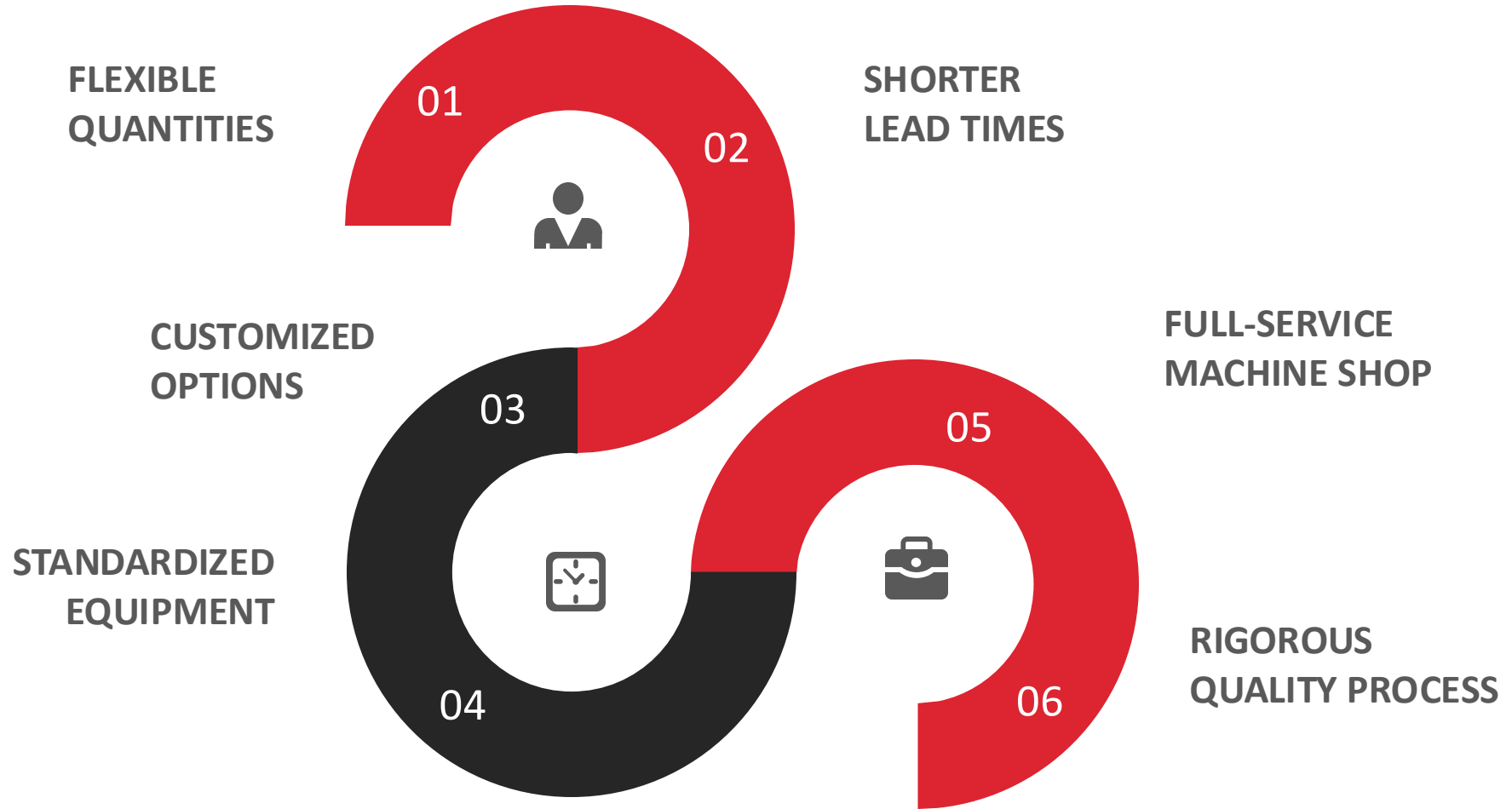



SUSTAINABILITY

We are a socially responsible company with a focus on sustainability.



VALIDATION

Our commitment to sustainability was validated by EcoVadis in 2024 with a Bronze Recognition Level.



BY THE NUMBERS

We are in the top 30% of over 50,000 global companies rated by the EcoVadis sustainability methodology.



SUSTAINABLE PACKAGING

Providing sustainable packaging solutions throughout the packaging lifecycle:

- Reducing Gram Weight
- Providing Returnable Bulk Packaging Options
- Reconfiguring Cartons to Lighter Board Grade
- Re-Shipper Packaging Available
- Utilizing Recycled Materials
- Alternative Options to PCV Available
- SKU Reductions
- Offering Re-Fillable/Reusable Containers
- Integrated Partitions



UN CERTIFIER

CL Smith Family of Solutions | Making Your Life Easier



MANUFACTURER



UN CERTIFIER



DESIGNER



DISTRIBUTOR



UN CERTIFIER

Engineer | Test & Certify | Manufacture | UN COMPLIANCE

PACKAGE DESIGN

Custom UN Packs
Hazardous Materials Experts

UN SELF-CERTIFIER

On-Site Testing UN/ISTA Testing Lab
Automated Re-Certification Process

MANUFACTURER

Stock Packaging
UN Manufactured Bottles



3

UN STOCK PACKAGING

Ready-to-ship hazardous material packaging solutions.

SPECIAL PERMIT



TIN CAN



PLASTIC



TEMPERATURE CONTROL

READY-TO-SHIP

- Special Permit
- 4GV/Variation 2
- Temperature Control
- Tin Can Packs
- Pail/Drum Packs
- Plastic Packs
- Single Packs
- Accessories

2

UN PACKAGING

Custom & Stock compliant hazardous material packaging solutions.



HAZARDOUS ARTICLES
4D WOOD BOXES



BATTERY PACKS



PYROTECHNICS



AEROSPACE

Rocket & Missile Packaging
Parachute With Class I Explosives



AVIATION

Batteries & Field Auxiliary
Power Supplies



EXPLOSIVES

Class I Explosive Motors
Guidance System With Class I Explosives



DESIGNER

CL Smith Family of Solutions | Making Your Life Easier



MANUFACTURER



UN CERTIFIER



DESIGNER



DISTRIBUTOR

2

CUSTOM DESIGNS

CAD Modeling & Rapid Prototyping

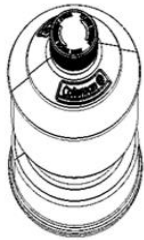

FLEXIBLE SIZES &
QUANTITIES

INNOVATIVE COLORS
& STYLES

PERFORMANCE
ORIENTED
PACKAGING

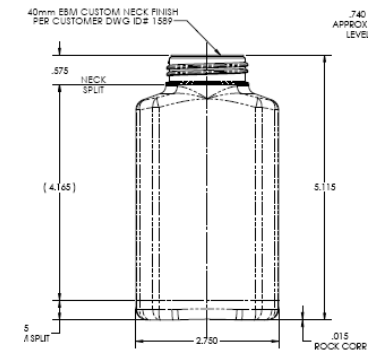
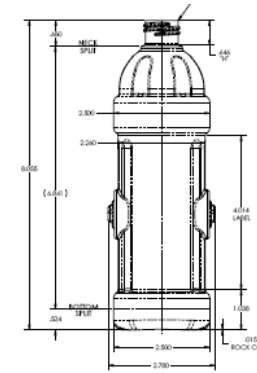
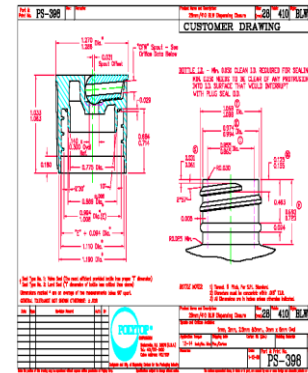

SUSTAINABLE
PACKAGING

RAPID PROTOTYPING
CAPABILITIES

Stereo Lithography
FDM Models
FOAM Prototyping

2

PRODUCT CREATIVITY

Custom design solutions that merge functionality with brand awareness.



Family of Trigger Sprayers
Stock Colors & Various
Sizes (12oz, 16oz, 24oz,
32oz)



Pet Industry Creative Design
Custom mold/label for Retail
Appeal



Captive Sprayer
Various Sizes & Same Insert



Dual Threaded Neck
For Custom Dispensing
System



Brand Family
Various Sizes/Styles



In-Line Sleeving
Custom Pearl White



Brand Family
NACD Silver Award: Shrink Sleeve,
Contour Shape, and Multiple
Closures, PET and HDPE



Translucent View Stripe
Incremental Graduations, Silk
Screen



DISTRIBUTOR

CL Smith Family of Solutions | Making Your Life Easier



MANUFACTURER



UN CERTIFIER



DESIGNER



DISTRIBUTOR

2

DISTRIBUTOR

Source, supply, manage, & distribute thousands of products at competitive prices.



- Plastic Bottles, Jars & Tubs
- Labels/Sleeves/Silkscreen
- Glass Bottles & Jars
- Closures & Sprayers
- Plastic & Steel Pails
- Poly & Steel Drums

- Fluorination Services
- Tin Cans
- FIBC's (Bulk Bags)
- UN Containers & Packaging
- Plastic Squeeze Tubes
- Cartons/Recons/Fiber Drums

- Accessories & Closing Tools
- Custom Molding & Decorating
- Clamshells, Blister Packs & Trays
- Injection Molded Parts
- Cartridges



PROVIDING VALUE

As your packaging partner, we provide value at every step of the packaging process.



OPENING NEW DOORS

Extensive line of complimentary industrial products, UN combination packaging, & in-house blow molding to help secure Mauser Drum Business.

FULL LINE STOCKING DISTRIBUTOR

CLS's financial fortitude allows for investment in turnkey supply chain management, warehousing & customized drum packaging. CLS has new warehouses for large volume customers with complex SKU mix and/or specialized delivery needs.

ROBUST LOGISTICS INFRASTRUCTURE

11 stocking warehouse facilities servicing 17 states in the Midwest. Facilitates same/next day service creating an abundance of opportunities for further expansion while the HAZPlus division has a coast to coast reach.

EXTENSIVE SALES FORCE

11 Person Sales Team (7 Sales Reps, 2 Inside Sales, Vice President of Business Development & Vice President of Sales) all laser-focused on growth.



NOVVIA GROUP

The new way of packaging!

Derived from the Latin words novus (new) and via (way), Novvia Group represents our commitment to setting a new industry standard as a national stocking distributor.

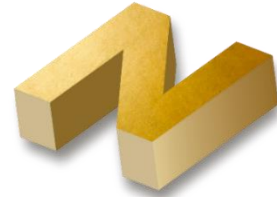

NOVVIA GROUP

THE NEW WAY OF PACKAGING

The Novvia Group is a leader in high-quality packaging solutions and customized services, with domestic and international customers across myriad industries. Through its family of dynamic companies, comprised of Inmark, C.L. Smith, Silver Spur, Container Supply, Fox Valley Container, Rhino Container, Novvia Group Canada, Southern Container, Rahway Steel Drum, Northern Container, Ocean State Packaging, and Liquid Bottles, Novvia has set a new industry standard as a national stocking distributor with a comprehensive suite of containers and supplies, trusted local relationships, and 40+ years of best-in-class customer service.



National Presence. Local Relationships.
Customized Solutions & Services.



Our Brands

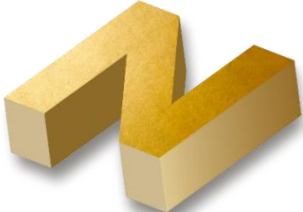

NOVVIA GROUP

THE NEW WAY OF PACKAGING



3

National Geographic Footprint

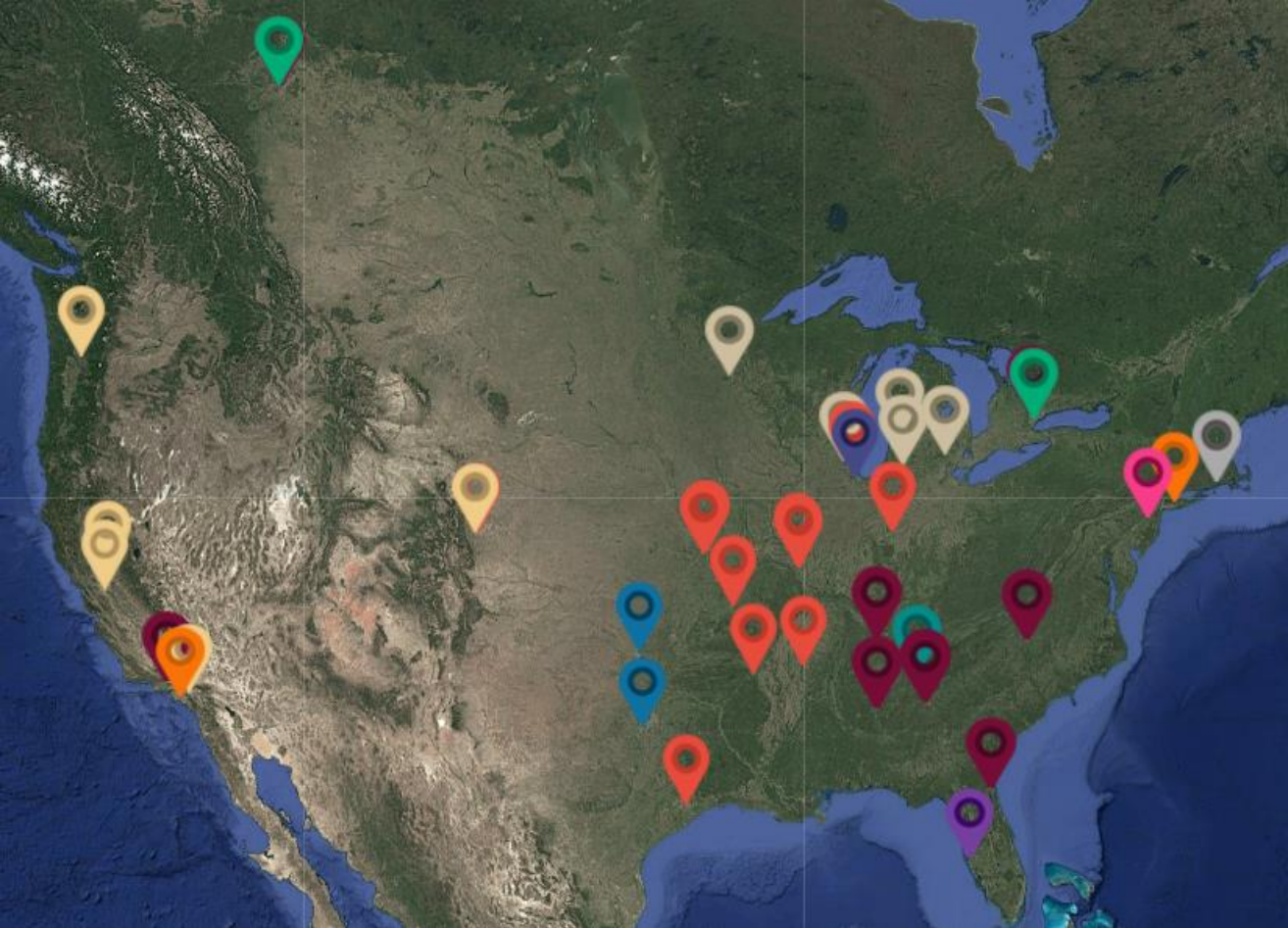

- Inmark Locations**
 - Austell, Georgia
 - Atlanta, Georgia
 - Birmingham, Alabama
 - Nashville, Tennessee
 - Jacksonville, Florida
 - High Point, North Carolina
 - Valencia, California
 - Edmonton, Alberta – Canada
 - Markham, Ontario – Canada
 - Raamsdonksveer, The Netherlands
 - Singapore
 - Shanghai, China (Acepac)

- Silver Spur Locations**
 - Cerritos, California
 - Hauppauge, New York

- Southern Container Locations**
 - Dalton, GA (3 Locations)

- Fox Valley Container Locations**
 - Crystal Lake, Illinois
 - Minneapolis, Minnesota
 - Schoolcraft, Michigan
 - Whitmore Lake, Michigan
 - Aurora, Colorado

- C.L. Smith Locations**
 - St. Louis, Missouri (2 Locations)
 - Berkeley, Missouri
 - Little Rock, Arkansas
 - Chicago, Illinois
 - Indianapolis, Indiana
 - Springfield, Missouri
 - Memphis, Tennessee
 - Houston, Texas
 - Denver, Colorado

- Container Supply Locations**
 - Oklahoma City, Oklahoma
 - Fort Worth, Texas

- Novvia Group Canada Locations**
 - Mississauga, Ontario
 - Edmonton, Alberta

- Rhino Container Locations**
 - Chino, California
 - Cerritos, California
 - Denver, Colorado
 - Vancouver, Washington

- Rahway Steel Drum Location**
 - Windsor, New Jersey

- Northern Container Location**
 - Alsip, IL

- Liquid Bottles**
 - Palmetto, FL



4

WRAP UP | Q&A

What questions can we answer today?



THANK YOU

